

OPTIMIZATION OF CROSSOVER FREQUENCY AND CROSSOVER REGION RESPONSE FOR MULTICHANNEL ACOUSTIC APPLICATIONS

Sunil Bharitkar and Chris Kyriakakis

Audyssey Laboratories, Inc.,
 Los Angeles, CA, USA
 phone: + (1) 310-268-8095, fax: + (1) 310-473-9803, email: sunil@audyssey.com
 web: http://www.audyssey.com

ABSTRACT

Given a multichannel loudspeaker system, in a typical single or multiple listener setup, the selection of the crossover frequency between the sub-woofer and the satellite speakers is important for accurate reproduction of playback sound from the corresponding channels. Specifically, the combined sub-woofer and satellite room acoustical response should exhibit negligible variations around the selected crossover frequency and simultaneously allow accurate rendition of audio from the respective channels. In many instances, even after selecting an appropriate crossover frequency, the final combined response may yet have substantial variations that further need to be minimized. In this paper, we present a two-stage approach for minimizing the variations in the combined sub-woofer and satellite room response measured at a given listening position for multichannel audio applications.

1. INTRODUCTION

A typical room is an acoustic enclosure that can be modelled as a linear system whose behavior at a particular listening position is characterized by an impulse response, $h(n); n \in \{0, 1, 2, \dots\}$. This is generally called the room impulse response and has an associated frequency response, $H(e^{j\omega})$, which is clearly a function of frequency (i.e., 20 Hz-20 kHz). Generally, $H(e^{j\omega})$ is also referred to as the room transfer function (RTF). The impulse response yields a complete description of the changes a sound signal undergoes when it travels from a source to a receiver (microphone/listener). The signal at a listening position consists of direct path components, discrete reflections that arrive a few milliseconds after the direct sound, as well as a reverberant field component. Essentially, a room response can be uniquely defined by a set of spatial co-ordinates $l_i \in \{x_i, y_i, z_i\}$. This assumes that the source is at origin and the receiver i is at the spatial co-ordinates, x_i, y_i and z_i , relative to a source in the room.

A typical 5.1 system is shown in Fig. 1, with a system level description in Fig.2, where the satellites are positioned surrounding the listener and the sub-woofer may be placed in the corner or near the edges of a wall. The bass management filters are standard used in the industry with a crossover frequency of 80 Hz (i.e., the 3 dB point), and the low-pass bass management filter that is applied to the sub-woofer is Butterworth in design having a roll-off rate of about 24 db/octave beyond 80 Hz, whereas the high-pass Butterworth filter applied to the satellites has a roll-off rate of about 12 dB/octave below 80 Hz. The frequency responses of the bass management filters, as well as the magnitude of the recombined response (i.e., the magnitude of the complex sum of the fil-

ter frequency responses), are shown in Fig. 3. Examples of other crossover networks that split the signal energy between the subwoofer and the satellites, according to predetermined crossover frequency and slopes, can be found in [1, 2, 3].

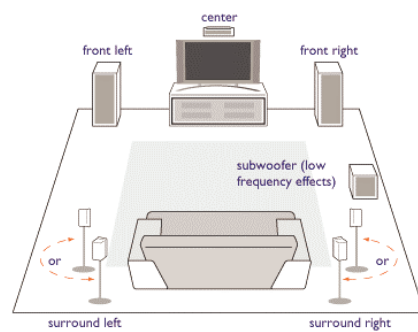

Figure 1: A 5.1 multichannel system.

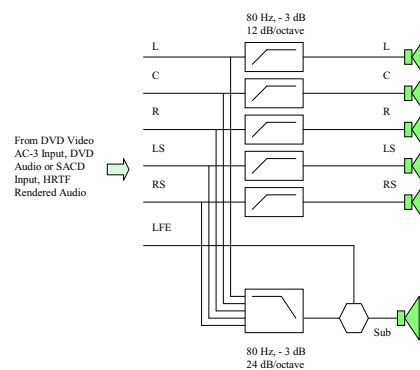

Figure 2: System level description of the 5.1 multichannel system of Fig. 1.

However, much of the loudspeaker systems are not designed with the 80 Hz crossover rule, and the crossover frequencies have to be intelligently determined depending on the speaker capabilities. While the crossover slopes too can be intelligently determined, the 24 dB/octave and 12 dB/octave slopes can be held constant to give adequately good performance as shown by the results in this paper. As an example, individual sub-woofer and satellite (in this case a center channel) frequency responses (1/3-rd octave smoothed), as measured in a room with a reverberation time $T_{60} \approx .75$ sec., are shown in Figs. 4(a) and 4(b) respectively. Clearly, the satellite is capable of playing audio below 100

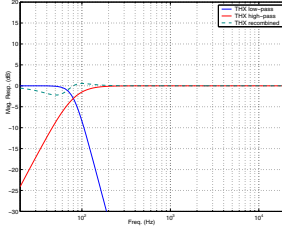

Figure 3: Magnitude response of the standard bass management filters and the recombined response.

Hz (up to about 40 Hz), whereas the sub-woofer is most efficient and generally used for audio playback at frequencies less than 200 Hz.

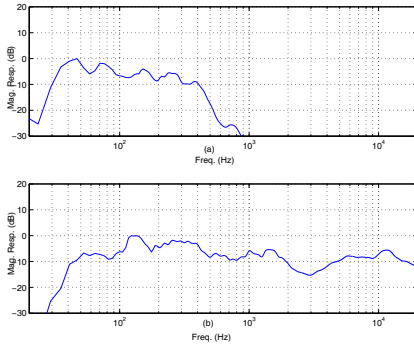

Figure 4: (a) Magnitude Response of the sub-woofer measured in a reverberant room, (b) magnitude response of the satellite measured in the same room.

Thus, due to the non-coincident positions of the various loudspeakers (e.g., the sub-woofer may be at one corner of the room and the center channel could be at a distance from the sub-woofer), if the crossover frequency is incorrectly selected, the complex addition of the sub-woofer and center channel responses could add incoherently thereby creating a large spectral notch in the crossover region at a listening position. This large spectral notch contributes to the loss in acoustical efficiency in playback sound, since much of the sound in this spectral region will be significantly attenuated. For example, as shown in Fig. 5, the resulting magnitude response obtained by summing the impulse responses has a severe spectral notch for a crossover frequency at 40 Hz (the low end frequency that the satellite is capable of playing). This has been verified through real measurements where the sub-woofer and the satellite channels were excited with a broadband stimuli (e.g., log-chirp signal) and subsequently de-convolving the net response from the measured signal.

While room equalization, as shown in Fig. 6, has been widely used to solve problems in the magnitude response (e.g., [4], [5]), these equalization filters do not necessarily solve the problems around the crossover frequency. In fact, many of these filters are minimum phase and as such may do little to influence the result around the crossover. However, while the techniques described in this paper are applied primarily to responses before equalization, these techniques can be readily applied after equalization to the filters from the afore-mentioned references.

Thus, in this paper, we present multiple approaches for

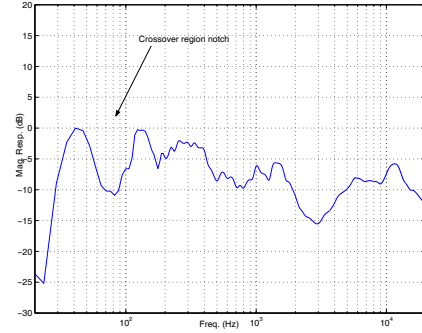

Figure 5: Magnitude of the net response obtained from using a crossover frequency of 40 Hz.

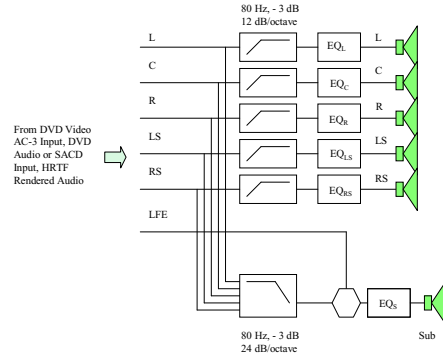

Figure 6: System level description of the 5.1 multichannel system of Fig. 1 with multiple listener equalization in each channel.

minimizing the variations due to phase interaction between non-coincident speakers for better magnitude response control around the crossover. The analysis and results presented in this paper does not include the situation where an equalization filter is present in each channel, however it is easy to extend the principles of this paper to this situation. Accordingly, section 2 presents an objective function based scheme, for selecting a crossover frequency, for minimizing the spectral notch in the magnitude response around the crossover. Results obtained from using this technique will also be presented. Section 3 presents an additional optimization method to further improve the performance over the method presented in section 2. Results are also presented in this section. Section 4 concludes the paper and presents future directions.

2. OBJECTIVE FUNCTION BASED CROSSOVER FREQUENCY SELECTION

For real-world applications, a typical home theater receiver includes a selectable (either by an user or automatically as shown by this paper) finite integer set of crossover frequencies, in 10 Hz increments, from 20 Hz through 200 Hz and 250 Hz (i.e., 20 Hz, 30 Hz, 40 Hz, ..., 200 Hz, 250 Hz). Thus, although the solution can be found through a gradient descent optimization, with respect the the 3 dB frequency of the Butterworth filter, where the objective function would be the error between the resulting magnitude response and unity around the crossover region, this is unnecessarily complicated. Clearly, the choice of the crossover frequency is

limited to this finite set of integers, hence a simpler and effective manner to select a proper choice of the crossover frequency is to characterize the effect of the choice of each of the selectable integer crossover frequency on the magnitude response around the crossover.

An objective function that is particularly useful for characterizing the magnitude response is the spectral deviation measure [4], [?]. Given that the effects of the choice of the crossover frequency are bandlimited around the crossover frequency, it will be shown that this measure is quite effective in predicting the behavior of the resulting magnitude response around the crossover. The spectral deviation measure, E , which indicates the degree of flatness of the spectrum is defined as: $E = \sqrt{\frac{1}{P} \sum_{i=0}^{P-1} (10 \log_{10} |E(e^{j\omega_i})| - \bar{E})^2}$ where $\bar{E} = \frac{1}{P} \sum_{i=0}^{P-1} 10 \log_{10} |E(e^{j\omega_i})|$ and $E(e^{j\omega}) = H_{sub}(e^{j\omega}) + H_{sat}(e^{j\omega})$, and P is the number of points selected around the crossover region. In this paper, the crossover region will be considered to be the frequency region between 30 Hz and 200 Hz, as the selectable crossover frequencies were chosen between 40 Hz and 170 Hz based on the loudspeaker capabilities (viz., neither the sub-woofer nor the satellite had significant output below 30 Hz as is evident from Fig. 4).

Figs. 7 and 8 show the resulting magnitude responses for different integer choices of the crossover frequencies from 30 Hz through 100 Hz. The spectral deviation values, as

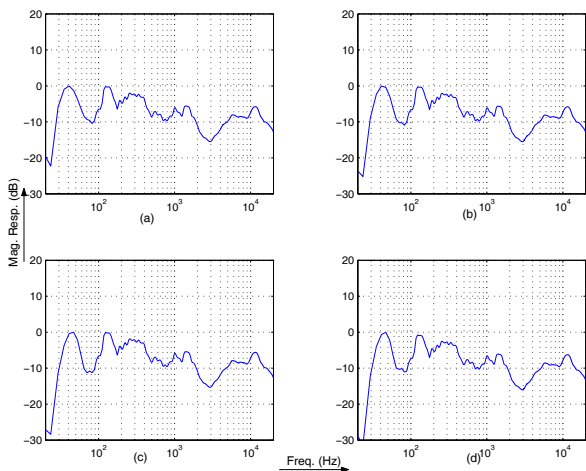

Figure 7: Plots of the resulting magnitude response from using crossover frequencies :(a) 30 Hz, (b) 40 Hz, (c) 50 Hz, (d) 60 Hz.

a function of the crossover frequency, for the crossover region around the crossover frequencies are shown in Fig. 9. Comparing Fig. 9 results with the plots in Figs. 7 and 8, it can be clearly seen that the spectral deviation measure can be used to characterize the performance in the crossover region for a given choice of crossover frequency. The best crossover frequency is then that which minimizes the spectral deviation measure, in the crossover region, over the integer set of crossover frequencies. In this example 90 Hz provided the best choice for the crossover frequency.

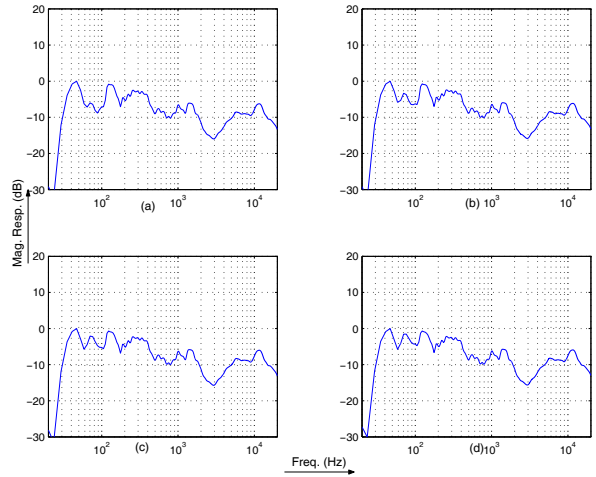

Figure 8: Plots of the resulting magnitude response from using crossover frequencies : (a) 70 Hz, (b) 80 Hz, (c) 90 Hz, (d) 100 Hz.

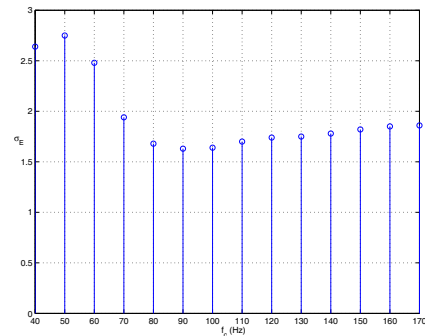

Figure 9: Spectral deviation versus crossover frequency.

3. OPTIMIZATION OF THE RESPONSE USING ALL-PASS FILTERS

In [7], we have shown that the phase interaction of the sub-woofer and the satellite around the crossover frequency can be minimized by placing an all-pass filter in the satellite channel and minimizing the phase term, expressed as $\angle_{sub}(\omega) - \angle_{sat}(\omega) - \angle_{AP}(\omega)$, where $\angle_{sub}(\omega)$, $\angle_{sat}(\omega)$, and $\angle_{AP}(\omega)$ are the phase spectrum of the sub-woofer, satellite, and all-pass filter cascade respectively. All-pass filters are well known to have a unit magnitude response and for introducing frequency dependent group delay. To combat the effects of incoherent addition of the sub-woofer and satellite responses, it was shown that it was preferable to include a second order all pass filter in the satellite channel (e.g., center channel). In contrast, if the all-pass cascade were to be placed in the sub-woofer channel, the net response between the sub-woofer and the remaining channels (e.g., left, right, and surrounds) could be affected in an undesirable manner. Thus, the all pass filter is cascaded with the satellite to remove the effects of phase between this satellite and the sub-woofer channel at a particular listening position. Without going into details (please refer to [7] for details), the update mechanism for determining the poles of the all-pass (characterized by r_i the magnitude of the pole, and θ_i the angle of the pole) for controlling the phase around the crossover region,

by minimizing the objective function $J(n)$, are as follows:

$$\mathcal{A}_M(e^j) = \prod_{k=1}^M \frac{e^{-j} - r_k e^{-j k}}{1 - r_k e^{j k} e^{-j}} \frac{e^{-j} - r_k e^{j k}}{1 - r_k e^{-j k} e^{-j}} \quad (1)$$

$$\mathcal{A}_M(\omega) = \prod_{k=1}^M \mathcal{A}_M^{(k)}(\omega) \quad (2)$$

$$\mathcal{A}_M^{(i)}(\omega) = -2 - 2 \tan^{-1} \left(\frac{r_i \sin(\omega - \theta_i)}{1 - r_i \cos(\omega - \theta_i)} \right) - 2 \tan^{-1} \left(\frac{r_i \sin(\omega + \theta_i)}{1 - r_i \cos(\omega + \theta_i)} \right)$$

$$J(n) = \frac{1}{N} \sum_{l=1}^N W(\omega_l) (\text{sub}(\omega_l) - \text{sat}(\omega_l) - \mathcal{A}_M(\omega_l))^2 \quad (3)$$

$$\begin{aligned} r_i(n+1) &= r_i(n) - \frac{r}{2} r_i J(n) \\ \theta_i(n+1) &= \theta_i(n) - \frac{\theta}{2} \theta_i J(n) \end{aligned} \quad (4)$$

where $W(\omega_l)$ is a frequency dependent weighting function chosen unity in the crossover region and care was taken to ensure the stability of the poles (viz., $r_i < 1$) and $M = 9$.

Fig. 10 shows an example of a resulting magnitude response of a sub-woofer and a satellite where 100 Hz was found to be the best choice using the spectral deviation measure. Additional optimization of the combined response, using an all-pass filter cascade in the satellite yielded better results with a lower E as indicated by the dashed curve. The spectral deviation measures for the two responses around the crossover were $E_{\text{original}} = 1.13$ and $E_{\text{AM}} = 0.61$, where E_{AM} was the measure with additional all-pass optimization.

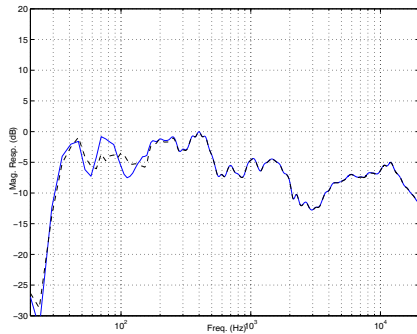

Figure 10: Blue (solid) curve is the resulting magnitude response from using crossover frequency 100 Hz as found by the minima of the E measure, whereas black (dashed) curve is the response after doing additional all-pass filter optimization.

4. CONCLUSIONS AND FUTURE DIRECTIONS

In this paper, we presented an optimization algorithm for selecting the best crossover frequency, from a finite integer set, using the spectral deviation criteria. It was shown that by performing additional optimization, using an all-pass cascade in

the satellite channel, the spectral deviation measure (or the deviations in the crossover region) of the resulting response can be further minimized. Future directions will be directed towards selecting a crossover frequency and optimizing the net response for multiple-listener (viz., multiple-response) applications.

5. ACKNOWLEDGEMENT

The author would like to thank Prof. Tom Holman for discussions on this topic.

REFERENCES

- [1] W. Woszczyk, "Bessel Filters as Loudspeaker Crossovers," *Proc. of 72nd AES Conv.*, 1982, (Preprint 1949).
- [2] S. Lipshitz and J. Vanderkooy, "A Family of Linear-Phase Crossover Networks of High Slope Derived by Time Delay," *Proc. of 69th AES Conv.*, 1981, (Preprint 1801).
- [3] N. Thiele, "Loudspeaker Crossovers with Notched Responses," *Proc. of 108th AES Conv.*, 2001, (Preprint 5106).
- [4] S. Bharitkar and C. Kyriakakis "A Cluster Centroid Method for Room Response Equalization at Multiple Locations," *Proc. of 2001 IEEE Workshop on Applications of Signal Processing to Audio and Acoustics (WASPAA 2001)*. New Paltz, NY. Oct. 2001.
- [5] M. Karjalainen, E. Piirilä, A. Järvinen, and J. Huopaniemi, "Comparison of loudspeaker response equalization using warped digital filters," in *Journal of Audio Eng. Soc.*, 47 (1/2), pp. 15-31, 1999.
- [6] J. Mourjopoulos, "On the variation and invertibility of room impulse response functions," *Journal of Sound and Vibration*, 102(2), pp. 217-228, 1985.
- [7] S. Bharitkar, "Phase Equalization for Multi-channel Loudspeaker-Room Responses," *Proc. 117th Audio Eng. Soc. Conv.*, San Francisco. Oct. 2004