

SEPARATION OF HEART SOUND SIGNAL FROM LUNG SOUND SIGNAL BY ADAPTIVE LINE ENHANCEMENT

Thato Tsalaile and Saeid Sanei

Centre of Digital Signal Processing, School of Engineering, Cardiff University
Cardiff, CF24 3AA, UK

Tel: +(44(0)29-2087-5946), Fax: +(44(0)29-2087-4716) Email: {tsalailatk, saneis}@cardiff.ac.uk
www.cardiff.ac.uk

ABSTRACT

This paper presents a technique for separation of heart sound signal (HSS) from lung sound signal (LSS) using adaptive line enhancement (ALE). The ALE is used to extract a semi-periodic signal component (HSS) from a synthetic white Gaussian noise (WGN). Application of ALE to separation of HSS from LSS has also been demonstrated. For when synthetic data (WGN) is combined with the HSS, it is found that ALE can separate the HSS at input signal-to-noise ratio (SNR_{in}) of 27dB. The results for when the ALE is applied to the combined HSS-LSS show that ALE can separate HSS even if the SNR_{in} equals -5 dB.

Keywords: Adaptive line enhancer, heart sound, lung sound

1. INTRODUCTION

Generally, all LSSs originate from airways during inspiration-expiration cycles [1]. The LSS propagates through lung tissues in the parenchyma and can be heard over the chest wall using a sound transducer. The tissue act as a frequency filter-like structure whose characteristics vary according to pathological and indeed physiological changes [1,2]. Besides the fact that normal and abnormal lung sounds are mixed in the air ways and therefore pose a problem of classification of respiratory diseases, semi-periodic HSS from heart beat activity invariably interfere with the LSS and therefore mask or inhibit clinical interpretation of LSS particularly over low frequency components. The main frequency components of HSS are in the range 20 – 100Hz. This is the range in which LSS has major components [3]. Therefore, since HSS and LSS overlap in frequency and, are somewhat non-stationary, the major problem being faced in separating HSS from LSS is, doing so without tempering with the main characteristic features of the LSS. This has been of interest to many researchers in the field of biomedical signal processing. Traditional bandpass filtering with arbitrary cut off frequencies of between 70 and 100 Hz [4], results in an inefficient performance since LSS has major components around this region especially at low flow rates. In [3], researchers have used adaptive filtering with a pre-processing stage comprising a variable amplifier gain. Other groups used an adaptive filter based on least mean square (LMS) algorithm to remove HS interferences [5]. In both cases mentioned above, researchers used HSS recorded from the patients' heart location as the reference signal for the adaptive system, which themselves are not free of the LSS. Along the same line, researchers in [6,7] have used an adaptive system with the ECG signal information as the reference signal. The discrepancy with this line of approach is the considerably high number of filter coefficients which results in a long adaptation gain. In a paper by Charleston and Azimi-Sadjadi [8], it is suggested to use a reduced order Kalman filtering technique (ROKF) for separation of signals based on the major assumption that HSS and LSS are mutually uncorrelated - These sounds may not be assumed uncorrelated since they stem from the same human physiological and metabolic changes. Also The ROKF is computationally costly [8]. Efforts have been made to eliminate the use of a reference signal when performing adaptive filtering. In

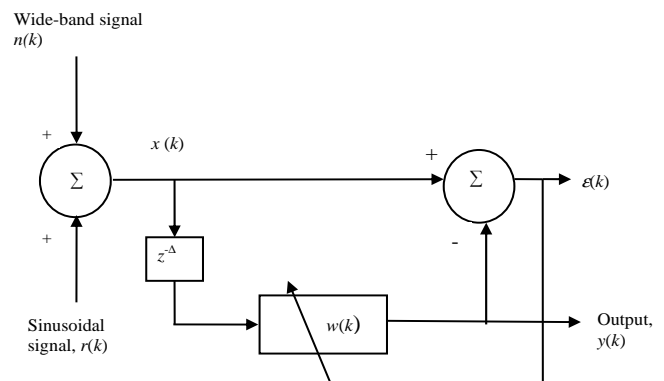

Figure 1: Adaptive Line Enhancer.

[9], a single recording based on the modified version of the adaptive LMS algorithm was proposed. Here, a lowpass filter with a cut off frequency of 250Hz was added in the error signal path. More recently, in [10], a recursive least squares (RLS)-based adaptive noise cancellation (ANC) filtering technique is proposed to separate or reduce the HSS from LSS. Here, a bandpass filtered version of the recorded LSS was used as the reference signal. Although experimental results are promising, the method however, suffers from high computational load. Time-Frequency (TF) filtering techniques have also been proposed for HSS reduction in LSS [11], [12], and [13]. It must be mentioned that the technique employed in [12] is found computationally efficient [12]. The objective of this paper is to use for the first time, the ALE to mitigate the HSS in LSS. This technique has found applications in spectral estimation, frequency estimation and detection [14] [15] [16], interference rejection [14], predictive deconvolution [17], and adaptive linear predictive coding [18].

2. ADAPTIVE LINE ENHANCEMENT

ALE was originally introduced by Wildrow *et al.* [14], and the configuration that implements adaptive line enhancement is called Adaptive Line Enhancer. It was coined adaptive line enhancer because of its ability to 'enhance' sinusoidal signals in the presence of wide-band noise [16]. The adaptive line enhancer has also been used to detect sinusoidal signals in "colored" noise [19].

The time domain representation of the ALE structure is shown in Figure 1. This structure is used in this project. The ALE comprises of L -weight linear predictive FIR filter. The ALE adaptively filters the delayed version of the input signal in accordance with the well known least-mean-square (LMS) adaptation algorithm of [20]. The time domain analysis of the structure is as follows:

$$x(k) = r(k) + n(k) \quad (1)$$

Where k is the sample time instance, $r(k)$ is the periodic sinusoidal signal and $n(k)$ is the broad-band noise signal

At any time instance k , the output $y(k)$ of the ALE is defined as:

$$y(k) = \sum_{l=0}^{L-1} w_k(k)x(k-l-\Delta) \quad (2)$$

Where Δ is the prediction distance of the filter in terms of the sampling interval, L is the filter length, and w_k are the ALE coefficients (FIR filter weights).

According to Wildrow *et al.* [14], $y(k)$ is an estimate of $r(k)$ provided the delay Δ exceeds the correlation time of $n(k)$. The delay Δ should be chosen equal to a lag for which the autocorrelation function of $n(k)$, $z_n(\tau)$ can be considered small relative to $z_n(0)$. Suffice to note that when dealing with sinusoidal signals in 'colored' noise, a relatively large value of the delay Δ , is often chosen [19]. The adaptive filter weights $w_k(l) = 0, \dots, L-1$ are chosen to minimise the mean squared error (MSE) defined as:

$$\xi = E[(x(k) - y(k))^2] \quad (3)$$

Now, since the only correlated component with $x(k)$ and its delayed versions, $x(k-\Delta), \dots, x(k-\Delta-L+1)$ is the underlying periodic signal $r(k)$ the MSE is minimised when $y(k) = x(k)$ [15]. In order to adjust the ALE coefficients the LMS algorithm [6] is preferably used due to its simplistic computation and robustness.

$$\mathbf{w}_{k+1} = \mathbf{w}_k + \mu \mathbf{x}_{k-\Delta} (x(k) - \mathbf{w}_k^T \mathbf{x}_{k-\Delta}) \quad (4)$$

Where $\mathbf{w}_k = [w_k(0), \dots, w_k(L-1)]^T$, and L is the length of the adaptive filter $\mathbf{x}_{k-\Delta} = [x(k-\Delta), \dots, x(k-\Delta-L+1)]$ is the ALE input vector, and μ is the ALE convergence rate.

The LMS for ALE and its properties have been discussed extensively in [20]. Most of the work on the ALE has centred on the determination of ALE filter coefficient vector \mathbf{w}_k , frequency response, and ALE convergence rate μ [21]. The performance analysis of adaptive line enhancement of real and complex signals in white noise has been discussed in [21] as well. There are three parameters that determine the performance of the LMS-ALE algorithm for a given application. These are ALE adaptive filter length L , the prediction distance Δ , and the LMS convergence parameter μ . Several performance criteria may be considered in choosing ALE parameters. These include; adaptation rate, excess mean squared error (EMSE) or misadjustment, and finally the frequency resolution. The adaptation rate is controlled by the choice of μ, L , and the condition of data vector autocorrelation [22]. Typically, the MSE for the LMS-ALE converges geometrically with a time constant $\tau_{LMS-ALE}$ [21] as:

$$\tau_{LMS-ALE} \approx \frac{1}{4\mu\lambda_{min}} \quad (5)$$

where λ_{min} is the minimum eigenvalue of the input vector autocorrelation matrix. Clearly, the convergence speed is proportional to the convergence rate μ . The EMSE ξ_{mis} , resulting from LMS algorithm's noisy estimate of the MSE gradient is approximately given by [21]

$$\xi_{mis} \approx \frac{\mu L \lambda_{av}}{2} \quad (6)$$

Where λ_{av} is the average eigenvalue of the input vector autocorrelation matrix. Since we have no control over λ_{av} (determined by input data), EMSE may be controlled by choosing values of μ and L . Smaller values of μ and L reduce the EMSE, while larger values increase the EMSE. The frequency resolution f_{res} , of the ALE is given in [21] as:

$$f_{res} = \frac{f_s}{L} \quad (7)$$

Where f_s is the sampling frequency. Hence, clearly, f_{res} may be controlled by L . Equation 6 in concert with Equation 7 shows that

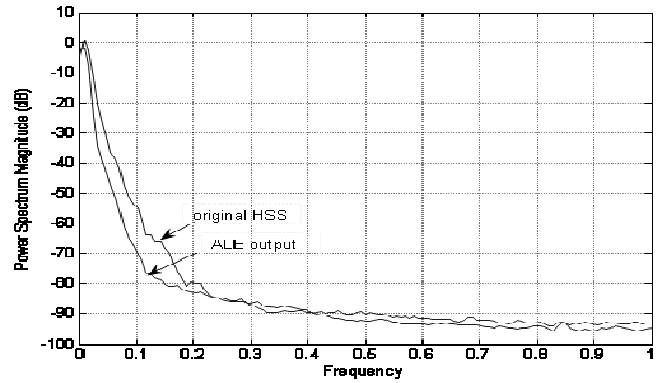

Figure 2: PSDs of the original HSS and recovered HSS, $SNR_{in} = 27dB$.

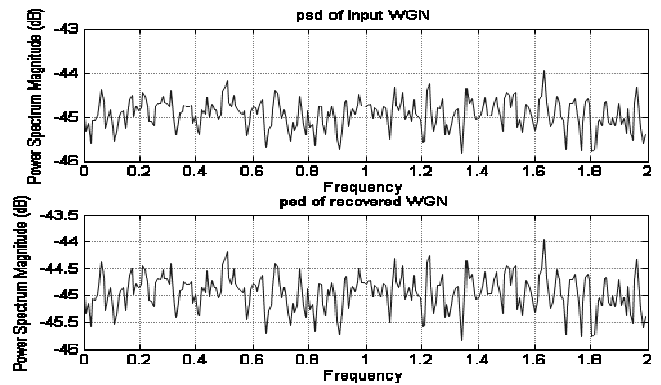

Figure 3: PSDs of the original WGN (top) and recovered WGN (bottom), $SNR_{in} = 27dB$.

larger values of L improve the f_{res} at the expense of an increase in EMSE, and smaller values reduce improves the EMSE at the expense of a reduction in f_{res} . The choice of the three parameters of μ, L , and Δ for our case is largely motivated by the performance criteria discussed here.

An expression for the SNR gain due to processing by the ALE for sinusoids in white noise has been given in [23]. For large L , the expression is simplified to

$$\frac{SNR_{out}}{SNR_{in}} = \frac{1}{\frac{2}{L} + \mu \xi_{min} L (1 + SNR_{in})} \quad (8)$$

where ξ_{min} is the minimum MSE. Clearly, decreasing μ increases the SNR gain at the expense of slower adaptation rate.

The ALE operation may be summarised as follows; the introduced delay, Δ , causes decorrelation between the noise components of the input signal in the delayed filtered version of $x(k)$ and the instantaneous $x(k)$ while introducing phase delay between the periodic signals. The adaptive filter responds by forming a transfer function equivalent to that of a narrow-band filter centred at the frequency of sinusoidal components. The noise component of the delayed input is rejected, while the phase difference of the periodic components is readjusted so that they cancel each other at the summing point, producing a minimum error signal composed of the noise component of the instantaneous input data alone.

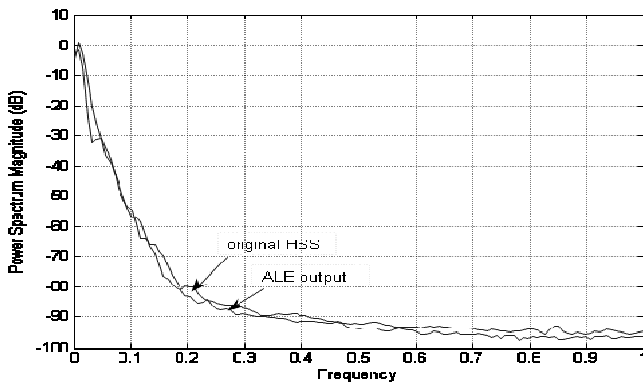

Figure 4: PSDs of the original HSS and recovered HSS, $SNR_{in} = 5dB$.

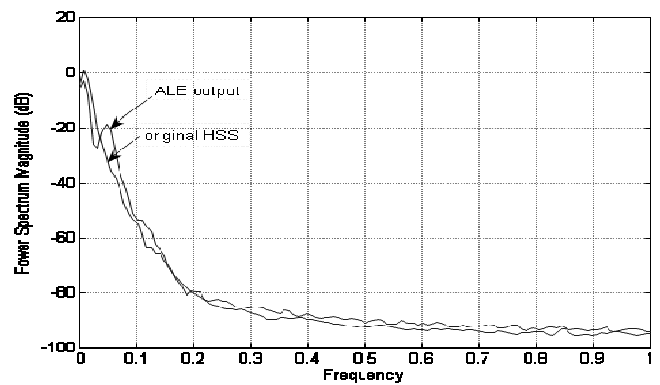

Figure 6: PSDs of the original HSS and recovered HSS, $SNR_{in} = -5dB$.

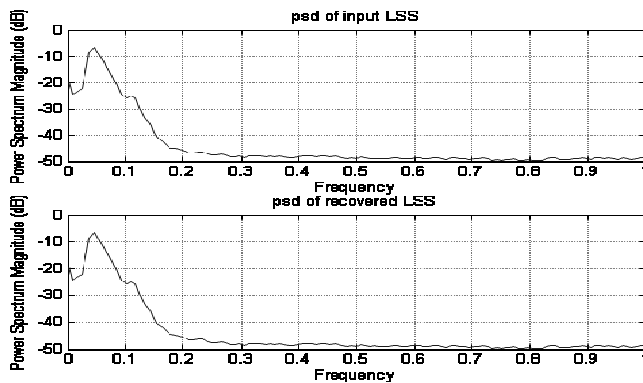

Figure 5: PSDs of the original LSS (top) and recovered LSS (bottom), $SNR_{in} = 5dB$.

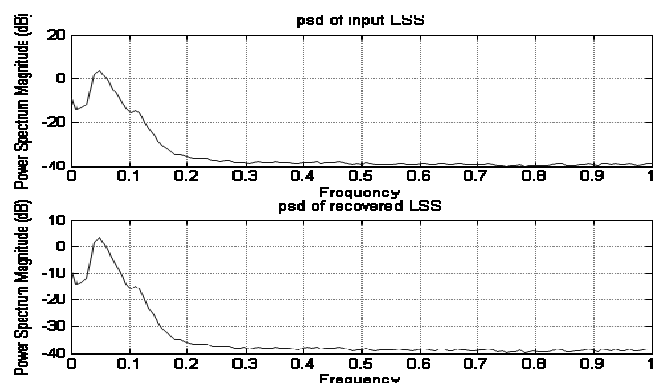

Figure 7: PSDs of the original LSS (top) and recovered LSS (bottom), $SNR_{in} = -5dB$.

3. EXPERIMENTAL RESULTS

In this section we demonstrate the ability of the ALE to recover HSS signal from the combined HSS-WGN signal as well as from the combined HSS-LSS signal. The aforementioned composite signals are applied to the ALE one at a time. Evaluation is done by comparing the power spectral densities (PSDs) at the input of the adaptive line enhancer and those of the recovered signals at the adaptive line enhancer output. The effectiveness of ALE is further confirmed by listening to the resulting recovered HSS and LSS to detect any artefacts. HSS and LSS data are obtained from R.A.L.E. data sets available at: www.rale.ca/.

3.1 HSS-WGN

The input signal to the ALE $x(k)$, is the noise-free HSS signal $r(k)$, corrupted by synthetic WGN $n(k)$, with SNR equal to 27dB. $x(k)$ was applied to the ALE of Figure 1 with ALE parameters $\mu = 0.0001$, $L=256$, and $\Delta = 15$. The PSDs of the recovered HSS $y(k)$ -ALE output, and that of $r(k)$ are compared in Figure 2. In Figure 3, we compare the PSD of the recovered WGN $\epsilon(k)$, with that of $n(k)$. From Figures 2 and 3, we observe that at SNR of 27dB, the PSD of the recovered HSS match that of the original, noise-free HSS. Also, the PSDs of the recovered WGN and that of the original synthetic WGN match. Thus, the power of both the original signals and the recovered signals are the same within all frequencies of interest.

3.2 HSS-LSS

The procedure outlined in Section 3.1 above was repeated with WGN replaced by a 'lung wheeze' LSS and SNR adjusted to 5dB and -5dB with ALE parameter settings of $\mu = 0.0001$, $L=256$, $\Delta = 15$ and $\mu = 0.0001$, $L=256$, $\Delta = 375$ respectively. Figures 4 and 5 show

PSD comparison for when SNR equals 5dB and Figures 6 and 7 show PSD comparison for a case when SNR equals -5dB. For both cases, PSDs show close resemblance in the entire frequency range. Figures 8 and 9 depict the comparison between the input HSS/LSS time signals and HSS/LSS output time signals for both cases SNR_{in} equals 5 and -5dB respectively.

4. DISCUSSIONS AND CONCLUSIONS

ALE is primarily used to extract a periodic signal component from additive white background noise without any knowledge of constituent frequencies of the periodic component and without making any assumptions *a priori* about signals' stationarity. ALE can also be applied to periodic signals in "colored" noise. For the same ALE parameter settings and SNR_{in}, application of ALE to HSS-WGN and HSS-LSS signals show better results in the latter case. It is evident from PSD plots of Figures 4 and 6 that the LSS is "colored". The EMSE of Equation 6 was derived under the assumption that the interfering signal is white. For "colored" or correlated noise, EMSE is smaller [15]. This explains the improved performance of the ALE when applied to HSS-LSS signal.

Application of the ALE to periodic signals in "colored" noise is characterized by longer prediction distances [25]. Figure 10 shows the autocorrelation function of the LSS. It can be seen that the autocorrelation function decays to a small value at a lag of about 400 samples relative to the zero lag $\zeta(0)$. Consistent with our discussion on choosing the prediction distance Δ , it is clear that choosing the prediction distance equal 375 for HSS-LSS signal improves the results.

ALE has been used as a new technique for separation of the HSS from LSS. The ALE method has the potential to separate HSS

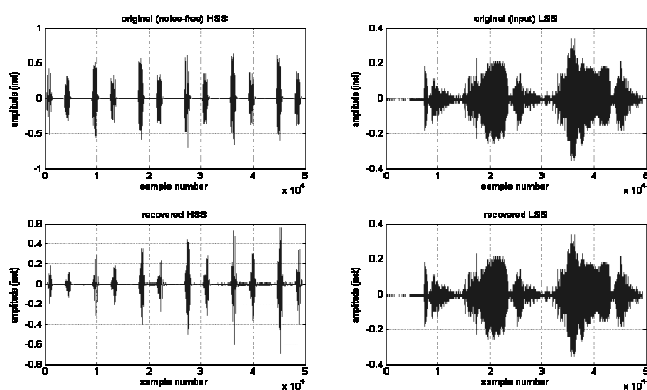

Figure 8: Time signals: the original HSS/LSS (top) and recovered HSS/LSS (bottom), $SNR_{in} = 5dB$.

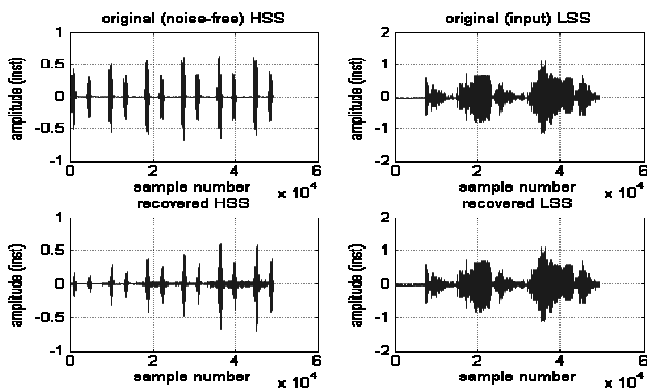

Figure 9: Time signals: the original HSS/LSS (top) and recovered HSS/LSS (bottom), $SNR_{in} = -5dB$.

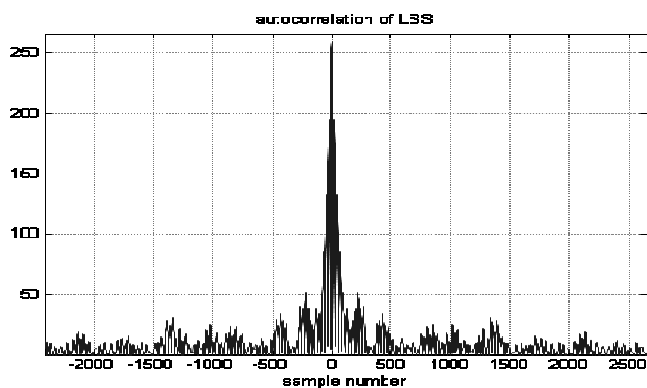

Figure 10: Autocorrelation of the LSS.

from LSS provided the LSS power in the combined HSS-LSS signal at the input of the adaptive line enhancer is within a 'manageable' level. It goes without saying that ALE may be used in a single channel recorded HSS-LSS signal for separation of the two. When dealing with HSS in the presence of WGN, the ALE works better at higher SNRs. For HSS in the presence of LSS (noise), the ALE performs even at lower SNRs. Increasing the prediction distance or the delay Δ of ALE may improve the results. This is demonstrated by a significant reduction in SNR from 5dB to -5dB when using $\Delta = 375$ instead of $\Delta = 15$. Finally, the results are sensitive to variations in the ALE parameters; therefore, for the best results they (ALE parameters) have to be chosen carefully.

REFERENCES

- [1] H. Pasterkamp, S. S. Kraman, and G. R. Wodicka, "Respiratory sounds: Advances beyond stethoscope," *Am. J. Respir. Crit. Care Med.*, vol. 156, no. 3, pp. 975-977, 1997.
- [2] F. Schuttler, T. Penzel, and P. V. Wichert, "Digital recording and computer-based analysis of lung sounds," in *Proc. 18th Ann. Int. Conf. IEEE EMBS*, pp. 2301-2302, 1997.
- [3] L. Yang-Sheng, L. Wen-Hui, and Q. Guang-Xia, "Removal of the heart sound noise from breath sound," in *Proc. 10th Ann. Int. Conf. IEEE EMBS*, pp. 175-176, 1988.
- [4] L. Vannuccinni, J. Earis, and P. Helisto, "Capturing and pre-processing of respiratory sounds," *Eur. Respir. Rev.*, vol. 10, no. 77, pp. 616-620, 2000.
- [5] L. Guangbin, C. Shaoqin, Z. Jingming, C. Jinzhi, and W. Shengju, "The development of a portable breath sound analysis system," in *Proc. 14th Ann. Conf. IEEE EMBS*, pp. 2582-2583, 1992.
- [6] K. Iyer, P. A. Ramamoorthy, H. Fang, and Y. Ploysongsang, "Reduction of heart sounds from lung sounds by adaptive filtering," *IEEE Trans. Biomed. Eng.*, vol. 33 no. 12, pp. 1141-1148, 1986.
- [7] L. Yip and Y. T. Zhang, "Reduction of heart sounds from lung sounds recording by automated gain control and adaptive filtering techniques," in *Proc. 23rd Ann. Int. Conf. IEEE EMBS*, pp. 2154-2156, 2001.
- [8] S. Charleston and M. R. Azimi-Sadjadi, "Reduced order Kalman filtering for the enhancement of respiratory sounds". *IEEE Trans. Biomed. Eng.*, vol. 43, no. 4, pp. 421-424, 1996.
- [9] M. Kompis and E. Russi, "Adaptive heart-noise reduction of lung sounds recorded by a single microphone," in *Proc. 14th Ann. Int. Conf. IEEE EMBS*, pp. 2416-2419, 2003.
- [10] J. Gnitecki, Z. Moussavi, and H. Pasterkamp, "Recursive least squares adaptive noise cancellation filtering for heart sound reduction in lung sounds recordings," in *Proc. 25th Ann. Int. Conf. IEEE EMBS*, vol. 3 pp. 2416-2419, 2003.
- [11] L. J. Hadjileontiadis and S. M. Panas, "A wavelet-based reduction of heart sound noise from lung sounds," *Int. J. Med. Info.*, vol. 52, no. 1-3, pp. 183-190, 1998.
- [12] M. T. Pourazad, Z. Moussavi, and G. Thomas, "Heart sound cancellation from lung sound recordings using time-frequency filtering," *IEEE Trans. Biomed. Eng.*, vol. 44, pp. 216-225, 2006.
- [13] M. T. Pourazad, Z. Moussavi, and G. Thomas, "Heart sound cancellation from lung sound recordings using adaptive threshold and 2D interpolation in time-frequency domain," in *Proc. 25th Ann. Int. Conf. IEEE EMBS*, pp. 2586-89, 2003.
- [14] B. Widrow, J. M. McCool, J. Kaunitz, C. S. Williams, R. H. Hearn, J. R. Zeidler, E. Dong, and R. C. Goodlin, "Adaptive noise cancelling: Principles and applications," in *Proc. Ann. Int. Conf. IEEE*, vol. 63, no. 12, pp. 1692-1716, 1975.
- [15] L. G. Griffiths, "Rapid measurement of digital instanta-

- neous frequency,” *IEEE Trans. Acoustics, Speech, and Signal Processing*, vol. 23, pp. 207-222, 1975.
- [16] J. R. Zeidler, E. Satorius, D. Chabries, and H. Wexler, “Adaptive enhancement of multiple sinusoids in uncorrelated noise,” *IEEE Trans. Acoustics, Speech, and Signal Processing*, vol. 26, pp. 240-254, 1978.
- [17] L. Griffiths, F. Smolka, and L. Trembly, “Adaptive deconvolution: A new technique for processing time-varying seismic data,” *Geophysics*, vol. 42, pp. 742-759, 1977.
- [18] D. Morgan and S. Craig, “Real-time adaptive linear prediction using the least mean squares gradient algorithm,” *IEEE Trans. Acoustics, Speech, Signal Processing*, vol. 23, pp. 207-222, 1976.
- [19] J. McCool and B. Widrow, “Principles and applications of adaptive filters: A tutorial view,” Naval Undersea Centre, San Diego, CA, Tech. Publ.530, 1977.
- [20] B. Widrow and M. Holf, “switching circuits,” in *IRE WESCON Conv. Rec.*, pp. 96-104, 1960.
- [21] J. Zeidler, “Performance analysis of LMS adaptive prediction filters,” in *Proc. Ann. Int. Conf. IEEE*, vol. 78, no. 12, pp. 1784-1793, 1990.
- [22] S. Haykin, *Adaptive filter theory*, New York: Prentice Hall, 1986.
- [23] J. Rickard and J. Zeidler, “Second-order output statistics of the adaptive line enhancer,” *IEEE Trans. Acoustics, Speech, and Signal Processing*, vol. 27, pp. 31-39, 1979.
- [24] E. D. Carlos, A. Alireza, and K. Alireza, “Estimation of single sweep steady-state visual evoked potentials by adaptive line enhancement,” *IEEE Trans. Biomed. Eng.*, vol. 41, no.2, pp.197-200, 1994.