

Prototyping of a hybrid 5GHz/60GHz OFDM WLAN system in the framework of IST-BroadWay

Markus Muck*, Philippe Bernardin*, Patrick Labbé*, Xavier Miet*, Dirk Pannicke†, Jens Schönthier†

*Motorola Labs, Espace Technologique, 91193 Gif-sur-Yvette, France

Email: {Markus.Muck,Philippe.Bernardin,Patrick.Labbe,Xavier.Miet}@motorola.com

†Dresden University of Technology, Communications Laboratory

01062 Dresden, Germany, Email: {pannicke,schoenthier}@ifn.et.tu-dresden.de

Abstract—In the framework of the IST-BROADWAY project, a hybrid 5GHz/60GHz WLAN system based on an Orthogonal Frequency Division Multiplexing (OFDM) modulation scheme has been defined. This contribution presents the results of the related prototyping efforts: the system concept is validated for the standard cyclic prefix OFDM (CP-OFDM) and the more advanced Pseudo Random Postfix OFDM (PRP-OFDM) modulation. Experimental results are presented concerning the received constellations of data tones after equalization, Carrier-to-Noise-plus-Interference-Ratio (C/I) estimates (approx. 20dB are achieved in average at 5GHz and approximately 12dB at 60GHz with the given experimental platform) and estimates of the 5GHz/60GHz channel impulse responses. As a conclusion, it will be shown that off-loading WLAN connections for a limited amount of time to the 60GHz band is a viable approach in order to improve the system availability and to assure very high throughputs.

I. INTRODUCTION

In the IST-BROADWAY project [1], a hybrid dual frequency system is defined based on a tight integration of IEEE802.11a/HiPerLAN/2 (based on the highly spectrum efficient OFDM modulation) technology at 5GHz [2] and an innovative fully ad-hoc extension at 60GHz named HIPERSPOT. This concept extends and complements existing 5GHz broadband wireless LAN systems in the 60GHz range for providing a new solution to very dense urban deployments and hot spot coverage. The resulting system guarantees nomadic terminal mobility in combination with higher capacity (achieving data rates exceeding 100Mbps). The new radio architecture will by construction inherently provide backward compatibility to current 5GHz WLANs (ETSI BRAN HiPerLAN/2 and IEEE802.11a).

This contribution presents the results of the prototyping efforts related to the IST-BROADWAY system definition including measurements of the C/I ratio in the receiver, illustrations of corresponding constellations and estimates of the channel impulse responses for both, 5GHz and 60GHz transmissions. As a main result, the system concept is shown to be valid and OFDM is proven to be a suitable choice at 60GHz, including the proposal of the novel Pseudo Random Postfix OFDM (PRP-OFDM) modulation scheme [3], [4].

This paper is organized as follows. Section II introduces the basic IST-BROADWAY base-band and Radio-Frequency (RF) system architecture and section III details the corresponding prototype implementation choices. The first step of the hardware verification consists in performing a digital loop-back transmission as presented in section IV; then, over-the-air transmissions are validated as documented in section V. Finally, section VI gives some concluding remarks.

II. THE IST-BROADWAY SYSTEM

The IST-BROADWAY base-band architecture is defined in [2] and illustrated by Fig. 2: incoming data bits are first scrambled, followed by forward error correction encoding based on convolutional coding, interleaving, mapping (optionally combined with spreading), pilot and zero insertion and modulation by an IFFT operation. Afterwards, the guard interval is added for the standard cyclic prefix OFDM (CP-OFDM) modulation or alternatively a pseudo-randomly weighted postfix sequence is used if PRP-OFDM is chosen instead. Training symbols are added prior to the data part of the frame. The implementation of the IST-BROADWAY prototype now requires a series of choices which are detailed in the following sections.

III. THE PROTOTYPING PLATFORM

The following paragraphs introduce i) the base-band platform we use for the development of the IST-BROADWAY prototype, some points on design methodology and base-band implementation choices and ii) a proposal of the RF front-end implementation including comments on the pros and cons of the inherent trade-offs.

A. The base-band platform

Our base-band platform is presented by Fig. 1 and Fig. 3. It is built on a custom PCI board including three main functionalities: the data flow controller, the digital signal processing core and the analog/digital (AD/DA) converters. The real time signal processing is implemented on an FPGA ALTERA 20K1500 providing 50000 programmable logic cells and 450K bits of memory, clocked at 50MHz. The FPGA transmitter and receiver designs include the automatic gain control (AGC), the synchronization, the OFDM engine and the digital I/Q modulator/demodulator. The base-band processor is connected to the radio front end via two AD/DA converters of 12 bits each, sampled at 80MHz. The FPGA designs also control the radio modules - to be detailed in the RF section III-B of this paper.

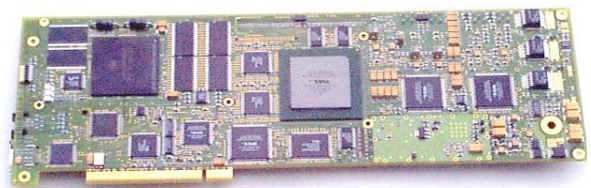

Fig. 1. Base-band Custom Platform.

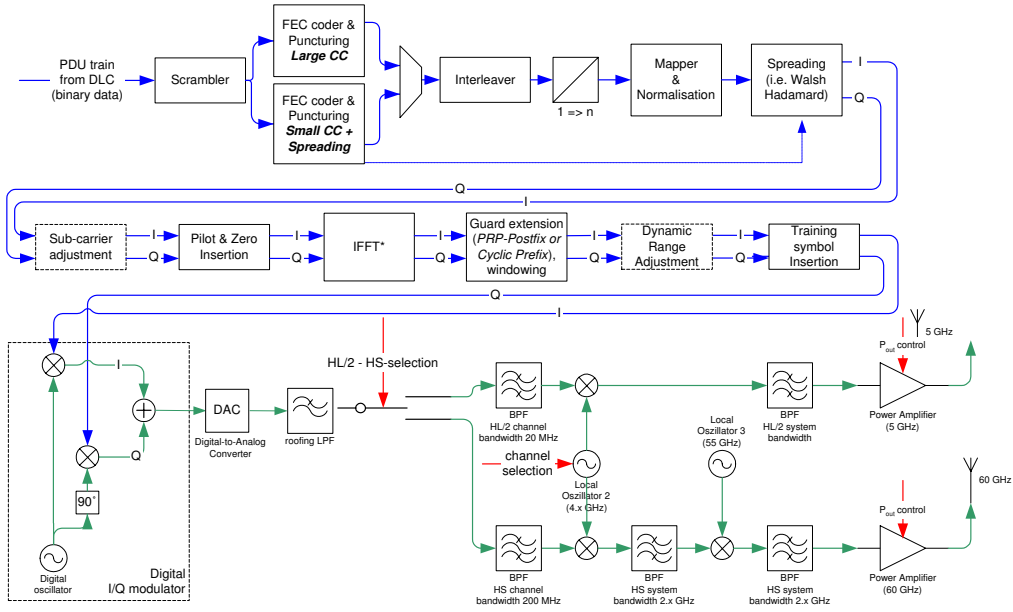

Fig. 2. The IST-BROADWAY transmitter architecture.

designs: one is dedicated to the testbed signal acquisition while the other one helps to validate the digital loop-back process of the CP-OFDM and PRP-OFDM modulators; in our implementation, the OFDM engine can easily switch from CP-OFDM to PRP-OFDM and vice versa thanks to embedded command registers. In addition, the transmitter uses a frame scenario player relying on an instruction pipelined sequencer. The system can operate the three common constellation types BSPK, QPSK and QAM-16. The base-band implementation for the test bed is illustrated in Fig. 4.

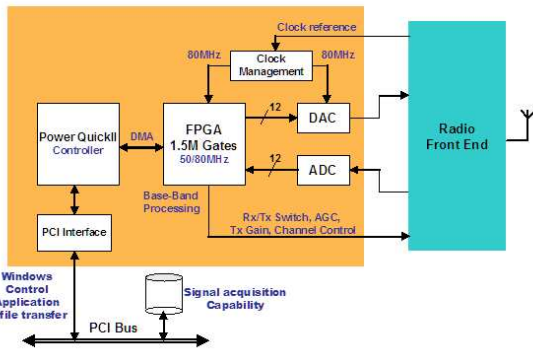

Fig. 3. Base-band Platform Overview.

1) *Base-Band processing implementation methodology:* The transmitter and receiver designs are based on proprietary blocks written in VHDL. We choose the development to be performed within three main steps: i) the algorithm level simulation (*Matlab & C++*), ii) the VHDL simulation and iii) the FPGA implementation. The validation of the test bed relies on a cross verification: simulation and implementation environments are compared via common scenarii and bit-accurate test vectors.

2) *Hybrid 5GHz/60GHz OFDM for the test bed:* The base-band processing design implemented in the FPGA relies on standard modules classically found in any CP-OFDM system. In addition, the hybrid 5GHz/60GHz OFDM prototype embeds several advanced designs, such as a digital I/Q modulator/demodulator, a signal acquisition system on the receiver side, a pipelined controller and in particular the PRP-OFDM mechanism at the transmitter side. Our prototype implementation uses a signal bandwidth of 20MHz, $N=64$ carriers (48 data carriers and 4 pilot tones) and a $D=16$ samples cyclic prefix (CP-OFDM) or postfix sequence (PRP-OFDM).

The base-band implementation of the receiver is split into two

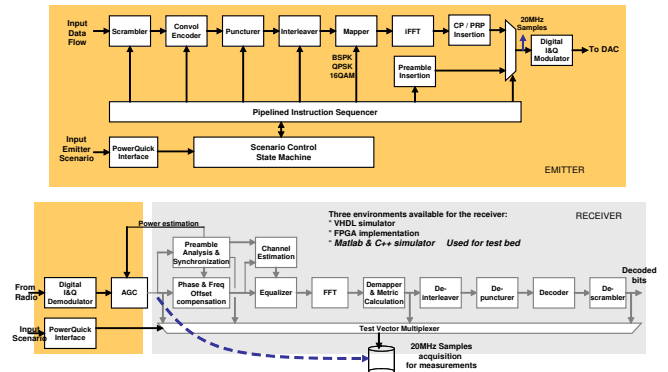

Fig. 4. Base-band implementation for the test bed.

3) *Digital I/Q implementation:* The RF front-end receives a real valued wave-form (i.e. hermitian symmetry is present in frequency domain) from which the complex base-band signal (In and Quadrature-phase (I/Q) components) needs to be extracted. In the transmitter, a dual problem is present, since the complex base-band signal must be transformed into a real analog one by imposing hermitian symmetry in frequency domain. Two main choices are available, here to be illustrated for the receiver: either the I/Q contributions are separated in analog or the digital I/Q separation performs the processing in digital relying on a higher sampling frequency. We choose to apply the latter solution: it

typically leads to a higher power consumption, but simplifies the analog part of modulators, avoids problems due to I/Q impairments as well as DC-offsets and gives more flexibility to the signal management. One inconvenience lies in the dimensioning of the AD/DA converters which need to run at a higher frequency: the IST-BROADWAY base-band platform embeds two 12 bits converters providing approx. 9 effective bits each at a sampling frequency of up to 100MHz, coupled to a high quality PLL module. Thus, the transmission only requires one radio up-converter with a real input. The integration of the digital I/Q in the OFDM chain is based on a symmetrical scheme between transmitter and receiver, requiring three steps: up/down-sampling, filtering and (de)modulation. The architecture is chosen to build on a polyphase filter. The ratio between i) the OFDM sampling frequency, ii) the digital carrier frequency and iii) the output sampling frequency greatly simplifies the implementation. The architecture of the digital I/Q modulator is given in Fig. 5.

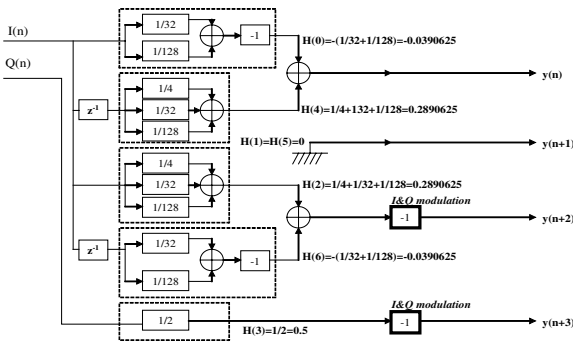

Fig. 5. Digital I/Q modulator.

4) *Test bed control application:* The PCI base-band board is controlled by a C application under MS-Windows. It allows to set any base-band parameters and frame scenarii. On the receiver side, the signal acquisition and analysis is handled by an additional Matlab environment including the OFDM demodulator chain for both, the CP-OFDM and PRP-OFDM modes. All commands and transfers initiated by the host PC are relayed by the PowerPC available on the board; we choose to run this CPU with the real time operating system (RTOS) VxWorks. The signal acquisition modules handled by the PowerPC allow to capture approx. six OFDM frames of 256 data symbols each.

B. The RF front-end and 60GHz antennas

The RF front-end used in IST-BROADWAY is a hybrid system able to work either at 5GHz or 60GHz at a time. We choose a super-heterodyn architecture where the intermediate frequency at 5GHz can be extracted for further use [5]. Thus, two separate blocks are distinguished: one operating from the base-band to 5GHz and the second operating from 5GHz to 60GHz.

1) *From base-band to 5GHz:* Compliant with the IEEE802.11a/HiPerLAN/2 definition of the PHY layer, the demonstrator architecture of the 5GHz part (presented in Fig. 6) uses an intermediate fixed frequency at 930MHz and a voltage controlled oscillator (VCO) at 4.2GHz to address several 20MHz channels between 5.15GHz and 5.35GHz. On the receiver side (RX), the chain embeds an automatic gain control (AGC) with a dynamic range of 80dB that pushes the overall sensitivity below -85dBm. On the transmitter side (TX), the output power is controlled by an

attenuator with 15dB of dynamic range followed by two power amplifiers (PA) in order to maintain the output power between -13dBm and +10dBm. At the antenna side, a classical dipolar antenna (compliant with the base station configuration) and an inverted F antenna (compatible with the integration at the mobile device) are used for the TX and the RX respectively.

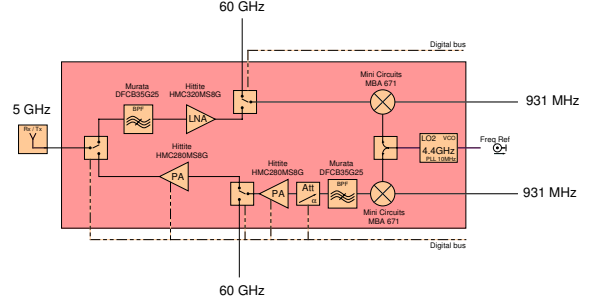

Fig. 6. RF front-end 5GHz sub-block architecture.

2) *From 5 to 60GHz:* The high frequency module has been designed by Farran Technologies. Its architecture is presented in Fig. 7 (see [6] for further details). Relying on the generation of the 5GHz signal (discussed in section III-B.1), this integrated system part up- and/or down-converts the signal to/from 60GHz using a 56GHz reference signal. Considering the importance of the phase noise in any OFDM system, care has been taken with respect to the choice of this reference: it is generated by an external phase locked dielectric resonance oscillator (PL-DRO) from Nexyn at 14GHz and is followed by an integrated frequency quadrupler. Such a solution exhibits an overall phase noise of -100dBc/Hz at 1kHz for the 14GHz part inducing a contribution to the final SNR below 40dB. The integration has been achieved using GaAs MMICs from TRW Inc. and custom designs using an advanced metamorphic InP process from WIN Inc. The discrete devices have been integrated on a duroid substrate in order to sustain temperature constraints. The overall system is able to operate from 59GHz to 62GHz with a total conversion gain between 15dB and 22.5dB at the TX side and a noise figure below 8dB at the RX side.

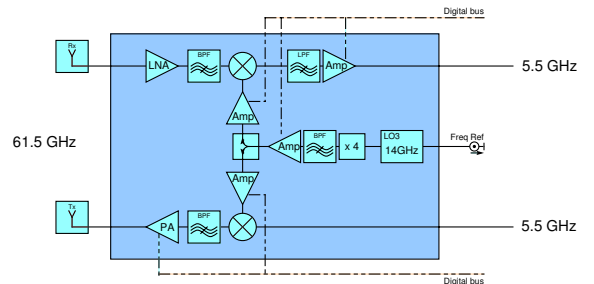

Fig. 7. RF front-end 60GHz sub-block architecture.

3) *Antennas:* Embedded on the 60GHz stage, two different types of antennas have been considered in compliance with the scenarii defined in Work Package (WP) 1 of IST-BROADWAY: a specific set of highly directive antennas designed by IMST GmbH is operating in the 60GHz range, with a gain superior to 20dBi in order to cope with the base station scenario (see Fig. 8). Two additional sets of omni-directional dual band antennas (able to

operate both at 5 and 60GHz) have been designed and realized by IRK GmbH. Their characterization was performed at the IMST facilities [7].

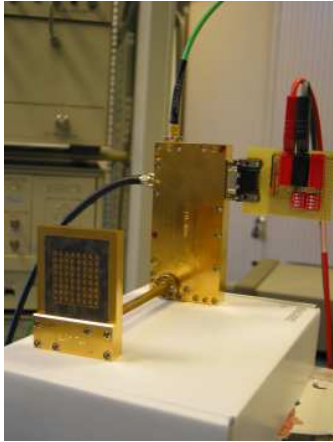

Fig. 8. 60GHz directive antenna ($> 20\text{dBi}$ gain) mounted on the 5-60GHz conversion block.

IV. VALIDATION OF THE DIGITAL LOOP-BACK

The base-band signal processing is implemented relying on the previously presented custom platform. In order to validate the VHDL design, we choose to pass through the following steps:

- 1) test VHDL-blocks using software simulation (e.g. [1]FFT, Viterbi decoder, synchronisation, etc.); all output vectors are compared to bit-accurate test-vectors in C++ and/or *Matlab*;
- 2) synthesize the blocks and check their behavior within the FPGA on the platform. During this process, the FPGA outputs must correspond exactly to the results of the bit-accurate simulations. This approach is valid for the TX as well as for the RX: concerning the TX, the signals at the output of the I/Q modulation (which feed the D/A-conversion) are read and validated.
- 3) afterwards, these reference signals are used to test the RX modules. They are stored in an internal memory of the platform and processed by the RX substituting real received data. This way, it is ensured that no interference due to D/A or A/D conversion is present. Processing results of the RX's base-band blocks are read and compared to the results of bit-accurate simulations.

The base-band loop-back allows to assure a satisfactory co-operation of the TX and RX without requiring any RF-front-end (i.e. 5GHz and 60GHz up/down converters, respectively). Unfortunately however, a simple connection of the TX outputs to the RX inputs is insufficient: as detailed in previous chapters, neither the analog front-ends of the TX nor RX deal with I/Q (de)modulation. Thus, digital I/Q (de)modulation at an IF of 20MHz is implemented on the base-band platform using an 80MHz sampling clock. Hence, the real-valued signal after the D/A conversion is centered around 20MHz with a 20MHz bandwidth.

It can be observed that the signal does not only consist in the desired in-band part in the frequency range from 10MHz to 30MHz, but also of additional unsuppressed images and modulation products. This is due to the overall concept of the IST BROADWAY demonstrator platform which performs channel

bandwidth limitation, channel selection and anti-aliasing filtering within the RF front-ends and not in the base-band/low-IF parts. Thus, a direct feed in of the low-IF to the inputs of the receiver's A/D converter (which again uses a 80MHz sample clock and digital I/Q separation) would lead to completely distorted constellation symbols in the RX (as shown in Fig. 10a). Regardless of this fact, a base-band loop-back was made possible by inserting an additional band-pass filter (Fig. 9) which sufficiently suppresses the undesired images and modulation products. The filter consists of a serial concatenation of a 5th-order low- and high-pass Chebyshev-filter.

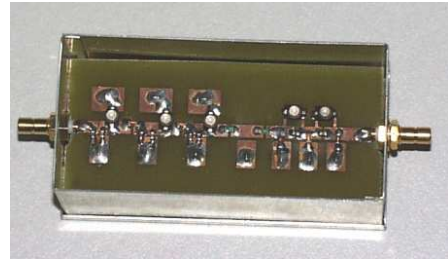

Fig. 9. Image-suppression band-pass.

As a result, the distorted QAM-16 constellations from Fig. 10a become proper in Fig. 10b. The remaining interferences (limiting the effective SNR in case of BER measurements) are due to an imperfect suppression of the undesired signal spectra and due to quantization noise. Nevertheless, this set-up enables the successful verification of correct time synchronisation and data flow within the base-band platform.

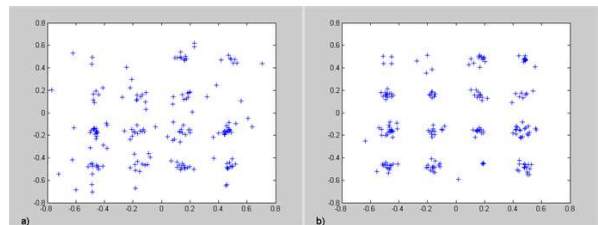

Fig. 10. Constellation diagrams for QAM-16 after C-field based channel estimation and equalisation a) without b) with band-pass filter.

V. VALIDATION OF THE 5GHz/60GHz CHAIN

The measurement results of the transmitter/receiver chain including the RF-frontends at 5GHz and 60GHz carrier frequency are illustrated by Fig. 11 through Fig. 18.

Fig. 11 and Fig. 12 illustrate typical channel impulse responses for the 5GHz and 60GHz transmission chains sampled at 20MHz. As expected, the 60GHz time domain channel impulse response (CIR) is slightly shorter compared to the 5GHz case. The similarities between both measurements indicate that the main contributions are introduced by the RF front-end filters of the transmitter and receiver. This observation is of great importance for the system design, since the guard interval length must be chosen taking the impulse responses of the front-end filters into account.

Fig. 13 and Fig. 14 illustrate the resulting Carrier-over-Noise-plus-Interference (C/I) ratio for 5GHz and 60GHz carrier frequencies and CP-OFDM vs PRP-OFDM based channel estimation after Zero Forcing (ZF) equalization and phase offset correction (2 measurements are given for each case): for CP-OFDM, the

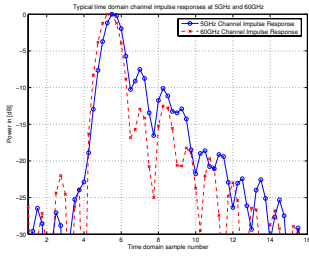

Fig. 11. Typical time domain channel impulse response at 5GHz and 60GHz.

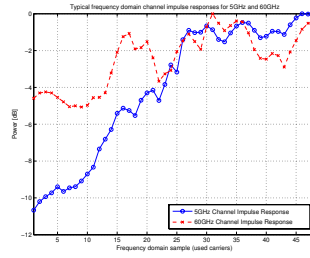

Fig. 12. Typical frequency domain channel impulse response at 5GHz and 60GHz.

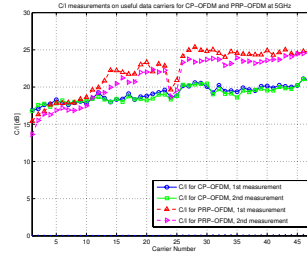

Fig. 13. Typical C/I for equalized and phase corrected constellation at 5GHz.

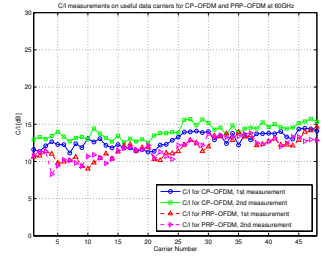

Fig. 14. Typical C/I for equalized and phase corrected constellation at 60GHz.

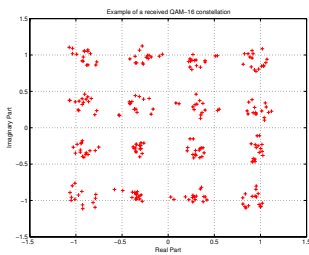

Fig. 15. Typical equalized QAM-16 constellation for CP-OFDM at 5GHz.

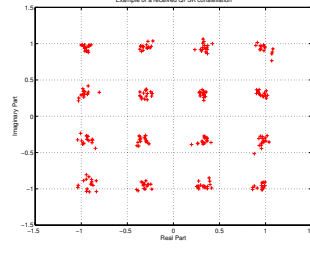

Fig. 16. Typical equalized QAM-16 constellation for PRP-OFDM at 5GHz.

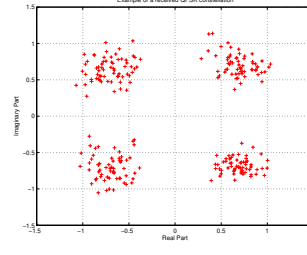

Fig. 17. Typical equalized QPSK constellation for CP-OFDM at 60GHz.

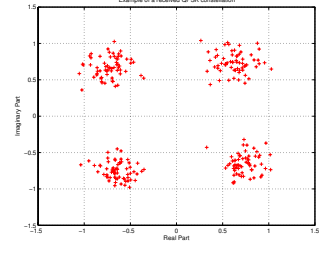

Fig. 18. Typical equalized QPSK constellation for PRP-OFDM at 60GHz.

CIR estimation is based on two learning symbols (C-Fields) and for PRP-OFDM (based on the simple Overlap-Add decoding technique) the CIR estimation is based on exploiting postfix sequences only as discussed in [3]. In the 5GHz case, the PRP-OFDM window size for CIR estimation (see [3]) is set to 240 OFDM symbols - in practice, this is a large value, but it illustrates well the potential of PRP-OFDM: Several dB are gained compared to CP-OFDM at the higher carrier band. For 60GHz, the results of PRP-OFDM are slightly below the ones for CP-OFDM; these results are already obtained for small window sizes (from approx. 16 OFDM symbols on), which indicates a rather poor acquisition SNR. Corresponding BER curves are not presented here for concision sake, but the results are close to the simulations given in [2]. These results validate the usefulness of PRP-OFDM if the target application requires: i) a minimum pilot overhead, ii) low-complexity channel tracking (e.g. high mobility context) and iii) adjustable receiver complexity/performance trade-offs without requiring any feed-back loop to the transmitter.

Examples of received QAM-16 constellations at a 5GHz carrier frequency and QPSK constellations at a 60GHz carrier frequency after ZF equalization are illustrated for CP-OFDM and PRP-OFDM in Fig. 15 to Fig. 18.

VI. CONCLUSION

This paper has shown a successful validation of the IST-BROADWAY system concept. The measured SNR values are sufficient for QAM-16 constellations at 5GHz and for QPSK at 60GHz; higher order constellations at 60GHz would require an improved RF design. Moreover, PRP-OFDM has been validated for the first time in a practical system.

ACKNOWLEDGEMENT

This work is supported by the European Commission and part of the IST BROADWAY project IST-2001-32686 [1]. Furthermore, hardware is re-used that was developed in the framework of the

French National Telecommunications Research Network (RNRT) project ANTIPODE.



Fig. 19. The IST-BROADWAY 5GHz Radio Front End.

REFERENCES

- [1] M. de Courville, S. Zeisberg, M. Muck, and J. Schoentier. BroadWay - the way to broadband access at 60GHz. In *International Conference on Telecommunication*, Beijing, China, June 2002.
- [2] Markus Muck, Jens Schönther, and Kai-Uwe Schmidt. Algorithm enhancement definition. Technical report, Deliverable D7R3 of IST-BROADWAY project IST-2001-32686, available at <http://www.ist-broadway.org>, 2004.
- [3] M. Muck, M. de Courville, M. Debbah, and P. Duhamel. A Pseudo Random Postfix OFDM modulator and inherent channel estimation techniques. In *GLOBECOM conference records*, San Francisco, USA, December 2003.
- [4] Markus Muck, Alexandre Ribeiro Dias, Marc de Courville, and Pierre Duhamel. A Pseudo Random Postfix OFDM based modulator for multiple antennae systems. In *Proceedings of the Int. Conf. on Communications*, 2004.
- [5] Emil Entchev, Rens Baggen, Sybille Holzwarth, Ralph Kluklas, Konstantin Kojucharow, David Bateman, and Patrick Labbé. Architecture proposal for RF front-end with special requirements on a dual 60GHz and 5GHz solution. Technical report, Deliverable D4 of IST-BROADWAY project IST-2001-32686, available at <http://www.ist-broadway.org>, 2004.
- [6] Emil Entchev and Patrick Labbé. Packaging of the 60GHz module. Technical report, Deliverable D18 of IST-BROADWAY project IST-2001-32686, available at <http://www.ist-broadway.org>, 2004.
- [7] Rens Baggen, Sybille Holzwarth, Ralph Kluklas, and Konstantin Kojucharow. Design and proof of the concept of antenna solution. Technical report, Deliverable D10 of IST-BROADWAY project IST-2001-32686, available at <http://www.ist-broadway.org>, 2004.